

# CBCS SCHEME

USN

--	--	--	--	--	--	--	--	--	--

15CS52

## Fifth Semester B.E. Degree Examination, Jan./Feb. 2021 Computer Networks

Time: 3 hrs.

Max. Marks: 80

Note: Answer any FIVE full questions, choosing ONE full question from each module.

### Module-1

- Explain the following terms : Reliable Data Transfer , Loss tolerant applications , Bandwidth sensitive applications , Elastic applications. (08 Marks)
  - Explain how recursive queries are resolved in Domain Name System. Illustrate DNS record structure and list any two types of records. (08 Marks)

OR

- Discuss Socket Communication between two processes that communicate over Internet with a block diagram. (08 Marks)
  - Explain (HTTP) Hyper Text Transfer Protocol request – response behavior. (08 Marks)

### Module-2

- Describe why an application developer might choose to run an application over UDP rather than TCP. (08 Marks)
  - Draw finite state machines for both sender side and receiver side of Go – back – N protocol and explain. (08 Marks)

OR

- Explain the structure of UDP and illustrate with an example the checksum calculation. (08 Marks)
  - Explain TCP connection management with time line diagrams. (08 Marks)

### Module-3

- Describe a high level view of a generic router architecture. (08 Marks)
  - Find the least cost path using Link – State Routing Algorithm in the network given in Fig.Q5(b). Assume node 'u' as the source node. Also state the algorithm. (08 Marks)

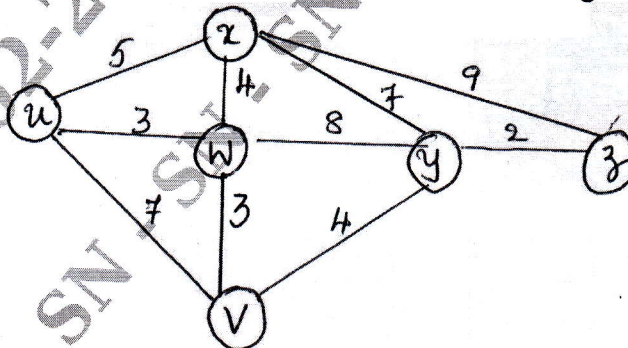
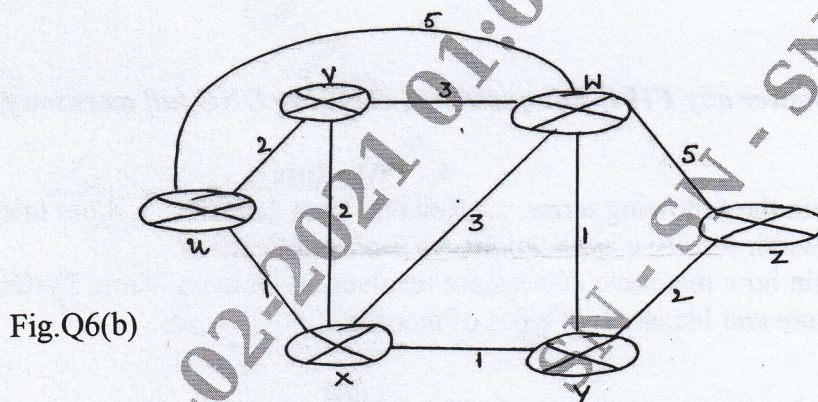

Fig.Q5(b)

OR

Important Note : 1. On completing your answers, compulsorily draw diagonal cross lines on the remaining blank pages.  
2. Any revealing of identification, appeal to evaluator and/or equations written eg. 42+8=50, will be treated as malpractice.

- 6 a. Explain the IPV4 datagram format. (08 Marks)  
 b. Discuss Distance Vector Routing algorithm. Find the least cost by using Distance Vector algorithm with 'u' as the source node in the network given in Fig. Q6(b). Show the routing table for node 'W'. (08 Marks)



#### Module-4

- 7 a. Explain 2G Cellular Architecture. (08 Marks)  
 b. What are the initial elements of a Mobile Network Architecture? Bring out the role of Care-of-address, permanent address and foreign address. (08 Marks)

OR

- 8 a. Describe how a call is placed to a mobile GSM user in a visited network. (08 Marks)  
 b. Explain Indirect routing to a mobile node. (08 Marks)

#### Module-5

- 9 a. Explain the service requirements and design issues in multimedia network applications. (08 Marks)  
 b. Explain Streaming of Stored video over HTTP/TCP. (08 Marks)

OR

- 10 a. What is a Content Distribution Network (CDN)? Explain how DNS is involved in CDN operation. (08 Marks)  
 b. Explain any two scheduling mechanisms as applicable to networks. (08 Marks)

\*\*\*\*\*